

# Preliminary Report

Fidelity National Title - LA

Title Officer:  
Email:  
Phone No.:  
File No.: 00370689

Property Address: 1745 Camino Palmero Street No. 107, Los Angeles, CA 90046

## Introducing



LiveLOOK title document delivery system is designed to provide 24/7 real-time access to all information related to a title insurance transaction.

Access title reports, exception documents, an easy-to-use summary page, and more, at your fingertips and your convenience.

[To view your new Fidelity National Title First Alert powered by LiveLOOK report, Click Here](#)



**Effortless, Efficient, Compliant, and Accessible**



# Fidelity National Title Company

5000 Van Nuys Blvd., Suite 500, Sherman Oaks, CA 91403  
Phone: (818) 881-7800

Issuing Policies of Fidelity National Title Insurance Company

ORDER NO.: **00370689-994-VNO-1AW**

LOAN NO.:

Title Officer: Albert Wassif  
Phone: (818) 881-7800 Ext. 5718  
Fax: (818) 745-5013  
Email: Team.Albert@fnf.com

Public Administrator Operations  
320 West Temple Street  
Los Angeles, CA 90012

ATTN: Bernardo Ochoa  
YOUR REF:

PROPERTY: **1745 Camino Palmero Street No. 107, Los Angeles, CA 90046**

## AMENDED PRELIMINARY REPORT

*In response to the application for a policy of title insurance referenced herein, **Fidelity National Title Company** hereby reports that it is prepared to issue, or cause to be issued, as of the date hereof, a policy or policies of title insurance describing the land and the estate or interest therein hereinafter set forth, insuring against loss which may be sustained by reason of any defect, lien or encumbrance not shown or referred to as an exception herein or not excluded from coverage pursuant to the printed Schedules, Conditions and Stipulations or Conditions of said policy forms.*

*The printed Exceptions and Exclusions from the coverage and Limitations on Covered Risks of said policy or policies are set forth in Attachment One. The policy to be issued may contain an arbitration clause. When the Amount of Insurance is less than that set forth in the arbitration clause, all arbitrable matters shall be arbitrated at the option of either the Company or the Insured as the exclusive remedy of the parties. Limitations on Covered Risks applicable to the CLTA and ALTA Homeowner's Policies of Title Insurance which establish a Deductible Amount and a Maximum Dollar Limit of Liability for certain coverages are also set forth in Attachment One. Copies of the policy forms should be read. They are available from the office which issued this report.*

*This report (and any supplements or amendments hereto) is issued solely for the purpose of facilitating the issuance of a policy of title insurance and no liability is assumed hereby. If it is desired that liability be assumed prior to the issuance of a policy of title insurance, a Binder or Commitment should be requested.*

*The policy(s) of title insurance to be issued hereunder will be policy(s) of Fidelity National Title Insurance Company, a Florida corporation.*

***Please read the exceptions shown or referred to herein and the exceptions and exclusions set forth in Attachment One of this report carefully. The exceptions and exclusions are meant to provide you with notice of matters which are not covered under the terms of the title insurance policy and should be carefully considered.***

***It is important to note that this preliminary report is not a written representation as to the condition of title and may not list all liens, defects and encumbrances affecting title to the land.***

Countersigned by:

*Cindy Fried*

Authorized Signature



# Fidelity National Title Company

5000 Van Nuys Blvd., Suite 500, Sherman Oaks, CA 91403  
Phone: (818) 881-7800

## AMENDED PRELIMINARY REPORT

---

**EFFECTIVE DATE:** January 16, 2024 at 7:30 a.m., Amended: February 9, 2024, Amendment No. 02

**ORDER NO.:** 00370689-994-VNO-1AW

The form of policy or policies of title insurance contemplated by this report is:

**ALTA Homeowner's Policy of Title Insurance (7-1-21)**  
**ALTA Extended Loan Policy (7-1-21)**

1. THE ESTATE OR INTEREST IN THE LAND HEREINAFTER DESCRIBED OR REFERRED TO COVERED BY THIS REPORT IS:

**A CONDOMINIUM, AS DEFINED IN SECTIONS 783 AND 4125 OF THE CALIFORNIA CIVIL CODE, IN FEE**

2. TITLE TO SAID ESTATE OR INTEREST AT THE DATE HEREOF IS VESTED IN:

**Charles Pendell, a single man**

3. THE LAND REFERRED TO IN THIS REPORT IS DESCRIBED AS FOLLOWS:

**See Exhibit A attached hereto and made a part hereof.**

**EXHIBIT A**  
**LEGAL DESCRIPTION**

THE LAND REFERRED TO HEREIN BELOW IS SITUATED IN THE CITY OF LOS ANGELES, COUNTY OF LOS ANGELES, STATE OF CALIFORNIA, AND IS DESCRIBED AS FOLLOWS:

A CONDOMINIUM COMPRISED OF:-

PARCEL 1:

ALL THAT PORTION OF LOT 1 OF TRACT NO. 35682, IN THE CITY OF LOS ANGELES, COUNTY OF LOS ANGELES, STATE OF CALIFORNIA, AS SHOWN ON MAP FILED IN MAP BOOK 936, PAGE(S) 88 AND 89 OF MAPS, RECORDS OF THE COUNTY OF LOS ANGELES, STATE OF CALIFORNIA, SHOWN AND DEFINED AS UNIT 107 ON THAT CERTAIN CONDOMINIUM PLAN RECORDED FEBRUARY 4, 1980 AS INSTRUMENT NO. 80-123232, OFFICIAL RECORDS OF LOS ANGELES COUNTY, CALIFORNIA.

PARCEL 2:

AN UNDIVIDED 1/131ST INTEREST IN AND TO ALL THAT PORTION OF SAID LOT 1 OF TRACT NO. 35682, IN THE CITY OF LOS ANGELES, SHOWN AND DEFINED AS COMMON AREA IN SAID CONDOMINIUM PLAN

[APN: 5550-001-046](#)

## EXCEPTIONS

### AT THE DATE HEREOF, ITEMS TO BE CONSIDERED AND EXCEPTIONS TO COVERAGE IN ADDITION TO THE PRINTED EXCEPTIONS AND EXCLUSIONS IN SAID POLICY FORM WOULD BE AS FOLLOWS:

1. Property taxes, which are a lien not yet due and payable, including any assessments collected with taxes to be levied for the fiscal year 2024-2025.

2. Property taxes, including any personal property taxes and any assessments collected with taxes, are as follows:

Code Area: 00067  
Tax Identification No.: [5550-001-046](#)  
Fiscal Year: 2023-2024  
1st Installment: \$877.06 Delinquent plus penalty \$87.70  
2nd installment: \$877.05 Open  
Exemption: \$7,000.00  
Land: \$23,792.00  
Improvements: \$112,349.00  
Personal Property: \$0.00  
Bill No.: None Shown

3. Said property has been declared tax defaulted for non-payment of delinquent taxes for the fiscal year 2021-2022

APN No.: 5550-001-046  
Default No.: Not Shown  
Default Date: June 30, 2021

Amounts to redeem for the above-stated fiscal year (and subsequent years, if any) are:

Amount: \$7,031.14, by: February 29, 2024  
Amount: \$7,106.15, by: March 31, 2024

4. An assessment by the improvement district shown below

Assessment (or Bond) No.: 1915 ACT  
Series: Ad #1  
District: County of Los Angeles  
For: Mrca-Brush Fire Clear'g Dist #1  
Bond Issued: August 6, 2003  
Original Amount: \$0.00

Said assessment is collected with the county/city property taxes.

5. The lien of supplemental or escaped assessments of property taxes, if any, made pursuant to the provisions of Chapter 3.5 (commencing with Section 75) or Part 2, Chapter 3, Articles 3 and 4, respectively, of the Revenue and Taxation Code of the State of California as a result of the transfer of title to the vestee named in Schedule A or as a result of changes in ownership or new construction occurring prior to Date of Policy.

Note: If said supplementals (if any) are not posted prior to the date of closing, this company assumes no liability for payment thereof.

6. Water rights, claims or title to water, whether or not disclosed by the public records.

**EXCEPTIONS  
(Continued)**

7. NOTICE: Certain cities in Los Angeles County impose a documentary transfer tax that is in addition to the Los Angeles County documentary transfer tax of \$.55 per \$500 (\$1.10 per \$1,000) based upon the purchase price or value of the property transferred. Additional transfer tax is imposed by the following cities in Los Angeles County:  
Culver City  
Los Angeles  
Pomona  
Redondo Beach  
Santa Monica  
For details about these taxes, please contact your title officer or escrow officer. Please be advised that, in the City of Santa Monica, effective March 1, 2023, for transfers of property with a sale price or value of \$8,000,000 or more, there will be a new, additional transfer tax of \$5.60 per \$100 (\$56.00 per \$1,000). In the City of Los Angeles, effective April 1, 2023, for transfers of property with a sale price or value of \$5,000,000 up to \$10,000,000, there will be a new, additional transfer tax of 4% of the entire sale price or value; for transfers with a sale price or value of \$10,000,000 or more, there will be a new, additional transfer tax of 5.5% of the entire sale price or value.
8. Easement(s) for the purpose(s) shown below and rights incidental thereto as delineated or as offered for dedication on the map of said tract.  
  
Purpose: public utilities  
Affects: a portion of said land
9. Provisions, herein recited, of the dedication statement on the map of the subdivision shown below  
  
Subdivision : Tract no. 35682  
provisions : which offers the land herein described for future street or alley and restrict the use thereof, affecting a 1 foot by 15.32 foot strip in the Northwest corner
10. The fact that the ownership of said land does not include rights of access to or from the street or highway abutting said land, such rights having been relinquished by the map of said Tract.  
  
Affects : Franklin avenue
11. An instrument entitled A Covenant and Agreement  
  
Executed by: Frank Horny, Et Al  
In favor of: City of Los Angeles  
Recording Date: December 29, 1972  
[Recording No.:](#) [1972-6536, of Official Records](#)  
  
Which among other things provides: as described therein  
  
Reference is hereby made to said document for full particulars.  
  
This covenant and agreement provides that it shall be binding upon any future owners, encumbrances, their successors or assigns, and shall continue in effect until the advisory agency approves termination.

**EXCEPTIONS  
(Continued)**

12. An instrument entitled A Covenant and Agreement

Executed by: Frank Horny, et Al  
In favor of: City of Los Angeles  
Recording Date: December 29, 1972  
[Recording No.:](#) [1972-6537, of Official Records](#)

Which among other things provides: As described therein

Reference is hereby made to said document for full particulars.

This covenant and agreement provides that it shall be binding upon any future owners, encumbrances, their successors or assigns, and shall continue in effect until the advisory agency approves termination.

13. An instrument entitled A Covenant and Agreement

Executed by: Briarwood Properties, Partnership, Ltd., a California Limited Partnership  
In favor of: City of Los Angeles  
Recording Date: September 7, 1979  
[Recording No.:](#) [1979-1004445, of Official Records](#)

Which among other things provides: As described therein

Reference is hereby made to said document for full particulars.

This covenant and agreement provides that it shall be binding upon any future owners, encumbrances, their successors or assigns, and shall continue in effect until the advisory agency approves termination.

14. An instrument entitled A Covenant and Agreement

Executed by: Briarwood Properties, Partnership, Ltd., a California Limited Partnership  
In favor of: City of Los Angeles  
Recording Date: November 16, 1979  
[Recording No.:](#) [1979-1295984, of Official Records](#)

Which among other things provides: As described therein

Reference is hereby made to said document for full particulars.

This covenant and agreement provides that it shall be binding upon any future owners, encumbrances, their successors or assigns, and shall continue in effect until the advisory agency approves termination.

15. Easement(s) for the purpose(s) shown below and rights incidental thereto as delineated or as offered for dedication on the map of said tract.

Purpose: Public utilities  
Affects: said land more particularly described therein

**EXCEPTIONS  
(Continued)**

16. The matters set forth in the document shown below which, among other things, contains or provides for: certain easements; liens and the subordination thereof; provisions relating to partition; restrictions on severability of component parts; and covenants, conditions and restrictions but omitting any covenants or restrictions, if any, including, but not limited to those based upon age, race, color, religion, sex, gender, gender identity, gender expression, sexual orientation, marital status, national origin, ancestry, familial status, source of income, disability, veteran or military status, genetic information, medical condition, citizenship, primary language, and immigration status, as set forth in applicable state or federal laws, except to the extent that said covenant or restriction is permitted by applicable law.

Entitled: Declaration of covenants, conditions and restrictions  
Recording Date: February 4, 1980  
[Recording No.:](#) [1980-123233, of Official Records](#)

Said covenants, conditions and restrictions provide that a violation thereof shall not defeat the lien of any mortgage or deed of trust made in good faith and for value.

17. The terms, covenants and conditions of that certain agreement which among other things, provides for an assignable, continuing right of first refusal in favor of the housing authority of the City of Los Angeles, to purchase the subject property provided for therein. Said agreement further provides that "developer or any subsequent purchaser from developer shall notify the housing authority in writing by certified or registered mail, with return receipt, of any intended authority shall have ten (10) days after receipt of sale to notify developer or successor in interest exercise this right of first refusal.

Recording Date:: February 6, 1980  
[Recording No.:](#) [1980-135396, official records](#)

18. A lien for the amount shown below and any other amounts due,

Amount: \$14,279.89  
Nature of Claim: Claim of Lien  
Recording Date: December 3, 2019  
[Recording No.:](#) [20131321283, of Official Records](#)

19. A homestead declaration

Executed By: Charles Ray Pendell  
Dated: April 22, 2019  
Recording Date: April 22, 2019  
[Recording No.:](#) [2019-0356429, of Official Records](#)

20. Intentionally Deleted.

21. An abstract of judgment for the amount shown below and any other amounts due:

Amount: \$8,653.67  
Debtor: Charles Pendell  
Creditor: Briarwood Owner's Association, Inc.  
Date Entered: July 16, 2001  
County: Los Angeles  
Court: superior  
Case No. 18STCV07346  
Recording Date: February 13, 2020  
[Recording No.:](#) [20200180035, of Official Records](#)



**EXCEPTIONS  
(Continued)**

22. Please be advised that our search did not disclose any open Deeds of Trust of record. If you should have knowledge of any outstanding obligation, please contact the Title Department immediately.

In order to close this pending transaction, we will need the following information:

- 1) Completion of the attached Owner's Declaration
- 2) Completed Escrow Owner Information Sheet
- 3) A statement from escrow providing the complete name of the account that proceeds are going to.

The Company reserves the right to add additional items and/or make further requirements after review of the requested documentation.

**PLEASE REFER TO THE "INFORMATIONAL NOTES" AND "REQUIREMENTS" SECTIONS WHICH FOLLOW FOR INFORMATION NECESSARY TO COMPLETE THIS TRANSACTION.**

---

**END OF EXCEPTIONS**

---

## REQUIREMENTS SECTION

1. In order to complete this report, the Company requires a Statement of Information to be completed by the following party(s),

Party(s):                      All Parties

The Company reserves the right to add additional items or make further requirements after review of the requested Statement of Information.

NOTE: The Statement of Information is necessary to complete the search and examination of title under this order. Any title search includes matters that are indexed by name only, and having a completed Statement of Information assists the Company in the elimination of certain matters which appear to involve the parties but in fact affect another party with the same or similar name. Be assured that the Statement of Information is essential and will be kept strictly confidential to this file.

---

**END OF REQUIREMENTS**

---

## INFORMATIONAL NOTES SECTION

1. Notice: Please be aware that due to the conflict between federal and state laws concerning the cultivation, distribution, manufacture or sale of marijuana, the Company is not able to close or insure any transaction involving Land that is associated with these activities.
2. None of the items shown in this report will cause the Company to decline to attach ALTA Endorsement Form 9 to an Extended Coverage Loan Policy, when issued.
3. Note: The Company is not aware of any matters which would cause it to decline to attach CLTA Endorsement Form 116 indicating that there is located on said Land a Condominium, known as 1745 Camino Palmero Street no. 107, Los Angeles, California to an Extended Coverage Loan Policy.
4. Note: The policy of title insurance will include an arbitration provision. The Company or the insured may demand arbitration provision. Arbitrable matters may include, but are not limited to any controversy or claim between the Company and the insured arising out of or relating to this policy, any service of the Company in connection with its issuance or the breach of a policy provision or other obligation. Please ask your escrow or title officer for a sample copy of the policy to be issued if you wish to review the arbitration provisions and any other provisions pertaining to your Title Insurance Coverage.
5. Note: There are NO conveyances affecting said Land recorded within 24 months of the date of this report.
6. Pursuant to Government Code Section 27388.1, as amended and effective as of 1-1-2018, a Documentary Transfer Tax (DTT) Affidavit may be required to be completed and submitted with each document when DTT is being paid or when an exemption is being claimed from paying the tax. If a governmental agency is a party to the document, the form will not be required. DTT Affidavits may be available at a Tax Assessor-County Clerk-Recorder.
7. Unless this company is in receipt of WRITTEN instructions authorizing a particular policy, Fidelity Title will AUTOMATICALLY issue the American Land Title Association Homeowner's Policy (02/03/10) for all qualifying residential 1-4 properties/transactions to insure the buyer at the close of escrow.
8. If a county recorder, title insurance company, escrow company, real estate broker, real estate agent or association provides a copy of a declaration, governing document or deed to any person, California law requires that the document provided shall include a statement regarding any unlawful restrictions. Said statement is to be in at least 14-point bold face type and may be stamped on the first page of any document provided or included as a cover page attached to the requested document. Should a party to this transaction request a copy of any document reported herein that fits this category, the statement is to be included in the manner described.
9. Any documents being executed in conjunction with this transaction must be signed in the presence of an authorized Company employee, an authorized employee of an agent, an authorized employee of the insured lender, or by using Bancserv or other approved third party service. If the above requirements cannot be met, please call the Company at the number provided in this report
10. NOTE: Amended Civil Code Section 2941, which becomes effective on January 1, 2002, sets the fee for the processing and recordation of the reconveyance of each Deed of Trust being paid off through this transaction at \$45.00. The reconveyance fee must be clearly set forth in the Beneficiary's Payoff Demand Statement ("Demand"). In addition, an assignment or authorized release of that fee, from the Beneficiary to the Trustee of record, must be included. An example of the required language is as follows:

The Beneficiary identified above hereby assigns, releases or transfers to the Trustee of record, the sum of \$45.00, included herein as 'Reconveyance Fees', for the processing and recordation of the Reconveyance of the Deed of Trust securing the indebtedness covered hereby, and the escrow company or title company processing this pay-off is authorized to deduct the Reconveyance Fee from this Demand and forward said fee to the Trustee of record or the successor Trustee under the Trust Deed to be paid off in full.

## **INFORMATIONAL NOTES** **(Continued)**

In the event that the reconveyance fee and the assignment, release or transfer are not included within the demand statement, then Fidelity National Title Insurance Company and its Underwritten Agent may decline to process the reconveyance and will be forced to return all documentation directly to the Beneficiary for compliance with the requirements of the revised statute.

11. Note: Part of the RESPA Rule to simplify and Improve the Process of Obtaining Mortgages and Reduce Consumer Settlement Costs requires the settlement agent to disclose the agent and underwriter split of title premiums, including endorsements as follows:

Line 1107 is used to record the amount of the total title insurance premium, including endorsements, that is retained by the title agent. Fidelity National Title Company retains 88% of the total premium and endorsements.

Line 1108 used to record the amount of the total title insurance premium, including endorsements, that is retained by the title underwriter. Fidelity National Title Insurance Company retains 12% of the total premium and endorsements.

12. The Company and its policy issuing agents are required by Federal law to collect additional information about certain transactions in specified geographic areas in accordance with the Bank Secrecy Act. If this transaction is required to be reported under a Geographic Targeting Order issued by FinCEN, the Company or its policy issuing agent must be supplied with a completed ALTA Information Collection Form ("ICF") prior to closing the transaction contemplated herein.

## INFORMATIONAL NOTES (Continued)

13. The following Exclusion(s) are added to preliminary reports, commitments and will be included as an endorsement in the following policies:
- A. 2006 ALTA Owner's Policy (06-17-06).
    - 1) Defects, liens, encumbrances, adverse claims, notices, or other matters not appearing in the Public Records but that would be disclosed by an examination of any records maintained by or on behalf of a Tribe or on behalf of its members.
  - B. 2006 ALTA Loan Policy (06-17-06).
    - 2) Defects, liens, encumbrances, adverse claims, notices, or other matters not appearing in the Public Records but that would be disclosed by an examination of any records maintained by or on behalf of a Tribe or on behalf of its members.
    - 3) Any claim of invalidity, unenforceability, or lack of priority of the lien of the Insured Mortgage based on the application of a Tribe's law resulting from the failure of the Insured Mortgage to specify State law as the governing law with respect to the lien of the Insured Mortgage.
  - C. ALTA Homeowner's Policy of Title Insurance (12-02-13) and CLTA Homeowner's Policy of Title Insurance (12-02-13).
    - 4) Defects, liens, encumbrances, adverse claims, notices, or other matters not appearing in the Public Records but that would be disclosed by an examination of any records maintained by or on behalf of a Tribe or on behalf of its members.
  - D. ALTA Expanded Coverage Residential Loan Policy - Assessments Priority (04-02-15).
    - 5) Defects, liens, encumbrances, adverse claims, notices, or other matters not appearing in the Public Records but that would be disclosed by an examination of any records maintained by or on behalf of a Tribe or on behalf of its members.
    - 6) Any claim of invalidity, unenforceability, or lack of priority of the lien of the Insured Mortgage based on the application of a Tribe's law resulting from the failure of the Insured Mortgage to specify State law as the governing law with respect to the lien of the Insured Mortgage.
  - E. ALTA Expanded Coverage Residential Loan Policy - Assessments Priority (04-02-15).
    - 7) Defects, liens, encumbrances, adverse claims, notices, or other matters not appearing in the Public Records but that would be disclosed by an examination of any records maintained by or on behalf of a Tribe or on behalf of its members.
  - 8) Any claim of invalidity, unenforceability, or lack of priority of the lien of the Insured Mortgage based on the application of a Tribe's law resulting from the failure of the Insured Mortgage to specify State law as the governing law with respect to the lien of the Insured Mortgage

**INFORMATIONAL NOTES**  
(Continued)

---

**END OF INFORMATIONAL NOTES**

---

Albert Wassif/909

---

## Wire Fraud Alert

This Notice is not intended to provide legal or professional advice. If you have any questions, please consult with a lawyer.

All parties to a real estate transaction are targets for wire fraud and many have lost hundreds of thousands of dollars because they simply relied on the wire instructions received via email, without further verification. **If funds are to be wired in conjunction with this real estate transaction, we strongly recommend verbal verification of wire instructions through a known, trusted phone number prior to sending funds.**

In addition, the following non-exclusive self-protection strategies are recommended to minimize exposure to possible wire fraud.

- **NEVER RELY** on emails purporting to change wire instructions. Parties to a transaction rarely change wire instructions in the course of a transaction.
- **ALWAYS VERIFY** wire instructions, specifically the ABA routing number and account number, by calling the party who sent the instructions to you. **DO NOT** use the phone number provided in the email containing the instructions, use phone numbers you have called before or can otherwise verify. **Obtain the phone number of relevant parties to the transaction as soon as an escrow account is opened.** **DO NOT** send an email to verify as the email address may be incorrect or the email may be intercepted by the fraudster.
- **USE COMPLEX EMAIL PASSWORDS** that employ a combination of mixed case, numbers, and symbols. Make your passwords greater than eight (8) characters. Also, change your password often and do **NOT** reuse the same password for other online accounts.
- **USE MULTI-FACTOR AUTHENTICATION** for email accounts. Your email provider or IT staff may have specific instructions on how to implement this feature.

For more information on wire-fraud scams or to report an incident, please refer to the following links:

**Federal Bureau of Investigation:**  
<http://www.fbi.gov>

**Internet Crime Complaint Center:**  
<http://www.ic3.gov>

# FIDELITY NATIONAL FINANCIAL, INC. PRIVACY NOTICE

**Effective January 1, 2023**

Fidelity National Financial, Inc. and its majority-owned subsidiary companies (collectively, “FNF,” “our,” or “we”) respect and are committed to protecting your privacy. This Privacy Notice explains how we collect, use, and protect personal information, when and to whom we disclose such information, and the choices you have about the use and disclosure of that information.

A limited number of FNF subsidiaries have their own privacy notices. If a subsidiary has its own privacy notice, the privacy notice will be available on the subsidiary’s website and this Privacy Notice does not apply.

## **Collection of Personal Information**

FNF may collect the following categories of Personal Information:

- contact information (e.g., name, address, phone number, email address);
- demographic information (e.g., date of birth, gender, marital status);
- identity information (e.g. Social Security Number, driver’s license, passport, or other government ID number);
- financial account information (e.g. loan or bank account information); and
- other personal information necessary to provide products or services to you.

We may collect Personal Information about you from:

- information we receive from you or your agent;
- information about your transactions with FNF, our affiliates, or others; and
- information we receive from consumer reporting agencies and/or governmental entities, either directly from these entities or through others.

## **Collection of Browsing Information**

FNF automatically collects the following types of Browsing Information when you access an FNF website, online service, or application (each an “FNF Website”) from your Internet browser, computer, and/or device:

- Internet Protocol (IP) address and operating system;
- browser version, language, and type;
- domain name system requests; and
- browsing history on the FNF Website, such as date and time of your visit to the FNF Website and visits to the pages within the FNF Website.

Like most websites, our servers automatically log each visitor to the FNF Website and may collect the Browsing Information described above. We use Browsing Information for system administration, troubleshooting, fraud investigation, and to improve our websites. Browsing Information generally does not reveal anything personal about you, though if you have created a user account for an FNF Website and are logged into that account, the FNF Website may be able to link certain browsing activity to your user account.

## **Other Online Specifics**

**Cookies.** When you visit an FNF Website, a “cookie” may be sent to your computer. A cookie is a small piece of data that is sent to your Internet browser from a web server and stored on your computer’s hard drive. Information gathered using cookies helps us improve your user experience. For example, a cookie can help the website load properly or can customize the display page based on your browser type and user preferences. You can choose whether or not to accept cookies by changing your Internet browser settings. Be aware that doing so may impair or limit some functionality of the FNF Website.

**Web Beacons.** We use web beacons to determine when and how many times a page has been viewed. This information is used to improve our websites.

**Do Not Track.** Currently our FNF Websites do not respond to “Do Not Track” features enabled through your browser.

**Links to Other Sites.** FNF Websites may contain links to unaffiliated third-party websites. FNF is not responsible for the privacy practices or content of those websites. We recommend that you read the privacy policy of every website you visit.

## **Use of Personal Information**

FNF uses Personal Information for three main purposes:

- To provide products and services to you or in connection with a transaction involving you.
- To improve our products and services.
- To communicate with you about our, our affiliates’, and others’ products and services, jointly or independently.

## **When Information Is Disclosed**

We may disclose your Personal Information and Browsing Information in the following circumstances:

- to enable us to detect or prevent criminal activity, fraud, material misrepresentation, or nondisclosure;
- to affiliated or nonaffiliated service providers who provide or perform services or functions on our behalf and who agree to use the information only to provide such services or functions;



- to affiliated or nonaffiliated third parties with whom we perform joint marketing, pursuant to an agreement with them to jointly market financial products or services to you;
- to law enforcement or authorities in connection with an investigation, or in response to a subpoena or court order; or
- in the good-faith belief that such disclosure is necessary to comply with legal process or applicable laws, or to protect the rights, property, or safety of FNF, its customers, or the public.

The law does not require your prior authorization and does not allow you to restrict the disclosures described above. Additionally, we may disclose your information to third parties for whom you have given us authorization or consent to make such disclosure. We do not otherwise share your Personal Information or Browsing Information with nonaffiliated third parties, except as required or permitted by law.

We reserve the right to transfer your Personal Information, Browsing Information, and any other information, in connection with the sale or other disposition of all or part of the FNF business and/or assets, or in the event of bankruptcy, reorganization, insolvency, receivership, or an assignment for the benefit of creditors. By submitting Personal Information and/or Browsing Information to FNF, you expressly agree and consent to the use and/or transfer of the foregoing information in connection with any of the above described proceedings.

### **Security of Your Information**

We maintain physical, electronic, and procedural safeguards to protect your Personal Information.

### **Choices With Your Information**

Whether you submit Personal Information or Browsing Information to FNF is entirely up to you. If you decide not to submit Personal Information or Browsing Information, FNF may not be able to provide certain services or products to you.

**For California Residents:** We will not share your Personal Information or Browsing Information with nonaffiliated third parties, except as permitted by California law. For additional information about your California privacy rights, please visit the “California Privacy” link on our website (<https://fnf.com/pages/californiaprivacy.aspx>) or call (888) 413-1748.

**For Nevada Residents:** We are providing this notice pursuant to state law. You may be placed on our internal Do Not Call List by calling FNF Privacy at (888) 714-2710 or by contacting us via the information set forth at the end of this Privacy Notice. For further information concerning Nevada’s telephone solicitation law, you may contact: Bureau of Consumer Protection, Office of the Nevada Attorney General, 555 E. Washington St., Suite 3900, Las Vegas, NV 89101; Phone number: (702) 486-3132; email: [aginqueries@ag.state.nv.us](mailto:aginqueries@ag.state.nv.us).

**For Oregon Residents:** We will not share your Personal Information or Browsing Information with nonaffiliated third parties for marketing purposes, except after you have been informed by us of such sharing and had an opportunity to indicate that you do not want a disclosure made for marketing purposes.

**For Vermont Residents:** We will not disclose information about your creditworthiness to our affiliates and will not disclose your personal information, financial information, credit report, or health information to nonaffiliated third parties to market to you, other than as permitted by Vermont law, unless you authorize us to make those disclosures.

**For Virginia Residents:** For additional information about your Virginia privacy rights, please email [privacy@fnf.com](mailto:privacy@fnf.com) or call (888) 714-2710.

### **Information From Children**

The FNF Websites are not intended or designed to attract persons under the age of eighteen (18). We do not collect Personal Information from any person that we know to be under the age of thirteen (13) without permission from a parent or guardian.

### **International Users**

FNF’s headquarters is located within the United States. If you reside outside the United States and choose to provide Personal Information or Browsing Information to us, please note that we may transfer that information outside of your country of residence. By providing FNF with your Personal Information and/or Browsing Information, you consent to our collection, transfer, and use of such information in accordance with this Privacy Notice.

### **FNF Website Services for Mortgage Loans**

Certain FNF companies provide services to mortgage loan servicers, including hosting websites that collect customer information on behalf of mortgage loan servicers (the “Service Websites”). The Service Websites may contain links to both this Privacy Notice and the mortgage loan servicer or lender’s privacy notice. The sections of this Privacy Notice titled When Information is Disclosed, Choices with Your Information, and Accessing and Correcting Information do not apply to the Service Websites. The mortgage loan servicer or lender’s privacy notice governs use, disclosure, and access to your Personal Information. FNF does not share Personal Information collected through the Service Websites, except as required or authorized by contract with the mortgage loan servicer or lender, or as required by law or in the good-faith belief that such disclosure is necessary: to comply with a legal process or applicable law, to enforce this Privacy Notice, or to protect the rights, property, or safety of FNF or the public.

### **Your Consent To This Privacy Notice; Notice Changes**

By submitting Personal Information and/or Browsing Information to FNF, you consent to the collection and use of the information in accordance with this Privacy Notice. We may change this Privacy Notice at any time. The Privacy Notice’s effective date will show the

last date changes were made. If you provide information to us following any change of the Privacy Notice, that signifies your assent to and acceptance of the changes to the Privacy Notice.

**Accessing and Correcting Information; Contact Us**

If you have questions or would like to correct your Personal Information, visit FNF's [Privacy Inquiry Website](#) or contact us by phone at (888) 714-2710, by email at [privacy@fnf.com](mailto:privacy@fnf.com), or by mail to:

Fidelity National Financial, Inc.  
601 Riverside Avenue  
Jacksonville, Florida 32204  
Attn: Chief Privacy Officer



# Fidelity National Title Company

5000 Van Nuys Blvd., Suite 500, Sherman Oaks, CA 91403  
Phone: (818) 881-7800 • Fax: (818) 776-8528

## Notice of Available Discounts

Pursuant to Section 2355.3 in Title 10 of the California Code of Regulations Fidelity National Financial, Inc. and its subsidiaries ("FNF") must deliver a notice of each discount available under our current rate filing along with the delivery of escrow instructions, a preliminary report or commitment. Please be aware that the provision of this notice does not constitute a waiver of the consumer's right to be charged the filed rate. As such, your transaction may not qualify for the below discounts.

You are encouraged to discuss the applicability of one or more of the below discounts with a Company representative. These discounts are generally described below; consult the rate manual for a full description of the terms, conditions and requirements for such discount. These discounts only apply to transactions involving services rendered by the FNF Family of Companies. This notice only applies to transactions involving property improved with a one-to-four family residential dwelling.

Not all discounts are offered by every FNF Company. The discount will only be applicable to the FNF Company as indicated by the named discount.

### FNF Underwritten Title Company

CTC – Chicago Title company  
CLTC – Commonwealth Land Title Company  
FNTC – Fidelity National Title Company of California  
FNTCCA - Fidelity National Title Company of California  
TICOR – Ticor Title Company of California  
LTC – Lawyer’s Title Company  
SLTC – ServiceLink Title Company

### Underwritten by FNF Underwriters

CTIC – Chicago Title Insurance Company  
CLTIC - Commonwealth Land Title Insurance Company  
FNTIC – Fidelity National Title Insurance Company  
FNTIC - Fidelity National Title Insurance Company  
CTIC – Chicago Title Insurance Company  
CLTIC – Commonwealth Land Title Insurance Company  
CTIC – Chicago Title Insurance Company

### Available Discounts

#### **DISASTER LOANS (CTIC, CLTIC, FNTIC)**

The charge for a Lender's Policy (Standard or Extended coverage) covering the financing or refinancing by an owner of record, within twenty-four (24) months of the date of a declaration of a disaster area by the government of the United States or the State of California on any land located in said area, which was partially or totally destroyed in the disaster, will be fifty percent (50%) of the appropriate title insurance rate.

#### **CHURCHES OR CHARITABLE NON-PROFIT ORGANIZATIONS (CTIC, FNTIC)**

On properties used as a church or for charitable purposes within the scope of the normal activities of such entities, provided said charge is normally the church's obligation the charge for an owner's policy shall be fifty percent (50%) to seventy percent (70%) of the appropriate title insurance rate, depending on the type of coverage selected. The charge for a lender's policy shall be forty (40%) to fifty percent (50%) of the appropriate title insurance rate, depending on the type of coverage selected.

## ATTACHMENT ONE (Revised 05-06-16)

### CALIFORNIA LAND TITLE ASSOCIATION STANDARD COVERAGE POLICY – 1990

#### EXCLUSIONS FROM COVERAGE

The following matters are expressly excluded from the coverage of this policy and the Company will not pay loss or damage, costs, attorneys' fees or expenses which arise by reason of:

1. (a) Any law, ordinance or governmental regulation (including but not limited to building or zoning laws, ordinances, or regulations) restricting, regulating, prohibiting or relating (i) the occupancy, use, or enjoyment of the land; (ii) the character, dimensions or location of any improvement now or hereafter erected on the land; (iii) a separation in ownership or a change in the dimensions or area of the land or any parcel of which the land is or was a part; or (iv) environmental protection, or the effect of any violation of these laws, ordinances or governmental regulations, except to the extent that a notice of the enforcement thereof or a notice of a defect, lien, or encumbrance resulting from a violation or alleged violation affecting the land has been recorded in the public records at Date of Policy.
- (b) Any governmental police power not excluded by (a) above, except to the extent that a notice of the exercise thereof or notice of a defect, lien or encumbrance resulting from a violation or alleged violation affecting the land has been recorded in the public records at Date of Policy.
2. Rights of eminent domain unless notice of the exercise thereof has been recorded in the public records at Date of Policy, but not excluding from coverage any taking which has occurred prior to Date of Policy which would be binding on the rights of a purchaser for value without knowledge.
3. Defects, liens, encumbrances, adverse claims or other matters:
  - (a) whether or not recorded in the public records at Date of Policy, but created, suffered, assumed or agreed to by the insured claimant;
  - (b) not known to the Company, not recorded in the public records at Date of Policy, but known to the insured claimant and not disclosed in writing to the Company by the insured claimant prior to the date the insured claimant became an insured under this policy;
  - (c) resulting in no loss or damage to the insured claimant;
  - (d) attaching or created subsequent to Date of Policy; or
  - (e) resulting in loss or damage which would not have been sustained if the insured claimant had paid value for the insured mortgage or for the estate or interest insured by this policy.
4. Unenforceability of the lien of the insured mortgage because of the inability or failure of the insured at Date of Policy, or the inability or failure of any subsequent owner of the indebtedness, to comply with the applicable doing business laws of the state in which the land is situated.
5. Invalidity or unenforceability of the lien of the insured mortgage, or claim thereof, which arises out of the transaction evidenced by the insured mortgage and is based upon usury or any consumer credit protection or truth in lending law.
6. Any claim, which arises out of the transaction vesting in the insured the estate of interest insured by this policy or the transaction creating the interest of the insured lender, by reason of the operation of federal bankruptcy, state insolvency or similar creditors' rights laws.

#### EXCEPTIONS FROM COVERAGE - SCHEDULE B, PART I

This policy does not insure against loss or damage (and the Company will not pay costs, attorneys' fees or expenses) which arise by reason of:

1. Taxes or assessments which are not shown as existing liens by the records of any taxing authority that levies taxes or assessments on real property or by the public records.  
Proceedings by a public agency which may result in taxes or assessments, or notices of such proceedings, whether or not shown by the records of such agency or by the public records.
2. Any facts, rights, interests, or claims which are not shown by the public records but which could be ascertained by an inspection of the land or which may be asserted by persons in possession thereof.
3. Easements, liens or encumbrances, or claims thereof, not shown by the public records.
4. Discrepancies, conflicts in boundary lines, shortage in area, encroachments, or any other facts which a correct survey would disclose, and which are not shown by the public records.
5. (a) Unpatented mining claims; (b) reservations or exceptions in patents or in Acts authorizing the issuance thereof; (c) water rights, claims or title to water, whether or not the matters excepted under (a), (b) or (c) are shown by the public records.
6. Any lien or right to a lien for services, labor or material not shown by the public records.

### CLTA HOMEOWNER'S POLICY OF TITLE INSURANCE (12-02-13) ALTA HOMEOWNER'S POLICY OF TITLE INSURANCE

#### EXCLUSIONS

In addition to the Exceptions in Schedule B, You are not insured against loss, costs, attorneys' fees, and expenses resulting from:

1. Governmental police power, and the existence or violation of those portions of any law or government regulation concerning:
  - a. building;
  - b. zoning;
  - c. land use;
  - d. improvements on the Land;
  - e. land division; and
  - f. environmental protection.This Exclusion does not limit the coverage described in Covered Risk 8.a., 14, 15, 16, 18, 19, 20, 23 or 27.
2. The failure of Your existing structures, or any part of them, to be constructed in accordance with applicable building codes. This Exclusion does not limit the coverage described in Covered Risk 14 or 15.
3. The right to take the Land by condemning it. This Exclusion does not limit the coverage described in Covered Risk 17.
4. Risks:
  - a. that are created, allowed, or agreed to by You, whether or not they are recorded in the Public Records;
  - b. that are Known to You at the Policy Date, but not to Us, unless they are recorded in the Public Records at the Policy Date;

- c. that result in no loss to You; or
  - d. that first occur after the Policy Date - this does not limit the coverage described in Covered Risk 7, 8.e., 25, 26, 27 or 28.
5. Failure to pay value for Your Title.
  6. Lack of a right:
    - a. to any land outside the area specifically described and referred to in paragraph 3 of Schedule A; and
    - b. in streets, alleys, or waterways that touch the Land.
 This Exclusion does not limit the coverage described in Covered Risk 11 or 21.
  7. The transfer of the Title to You is invalid as a preferential transfer or as a fraudulent transfer or conveyance under federal bankruptcy, state insolvency, or similar creditors' rights laws.
  8. Contamination, explosion, fire, flooding, vibration, fracturing, earthquake, or subsidence.
  9. Negligence by a person or an Entity exercising a right to extract or develop minerals, water, or any other substances.

**LIMITATIONS ON COVERED RISKS**

Your insurance for the following Covered Risks is limited on the Owner's Coverage Statement as follows:

- For Covered Risk 16, 18, 19, and 21 Your Deductible Amount and Our Maximum Dollar Limit of Liability shown in Schedule A.

The deductible amounts and maximum dollar limits shown on Schedule A are as follows:

	<b>Your Deductible Amount</b>	<b>Our Maximum Dollar Limit of Liability</b>
Covered Risk 16:	1.00% of Policy Amount Shown in Schedule A or \$2,500.00 (whichever is less)	\$ 10,000.00
Covered Risk 18:	1.00% of Policy Amount Shown in Schedule A or \$5,000.00 (whichever is less)	\$ 25,000.00
Covered Risk 19:	1.00% of Policy Amount Shown in Schedule A or \$5,000.00 (whichever is less)	\$ 25,000.00
Covered Risk 21:	1.00% of Policy Amount Shown in Schedule A or \$2,500.00 (whichever is less)	\$ 5,000.00

**2006 ALTA LOAN POLICY (06-17-06)**

**EXCLUSIONS FROM COVERAGE**

The following matters are expressly excluded from the coverage of this policy, and the Company will not pay loss or damage, costs, attorneys' fees, or expenses that arise by reason of:

1. (a) Any law, ordinance, permit, or governmental regulation (including those relating to building and zoning) restricting, regulating, prohibiting, or relating to
  - (i) the occupancy, use, or enjoyment of the Land;
  - (ii) the character, dimensions, or location of any improvement erected on the Land;
  - (iii) the subdivision of land; or
  - (iv) environmental protection;
 or the effect of any violation of these laws, ordinances, or governmental regulations. This Exclusion 1(a) does not modify or limit the coverage provided under Covered Risk 5.
- (b) Any governmental police power. This Exclusion 1(b) does not modify or limit the coverage provided under Covered Risk 6.
2. Rights of eminent domain. This Exclusion does not modify or limit the coverage provided under Covered Risk 7 or 8.
3. Defects, liens, encumbrances, adverse claims, or other matters
  - (a) created, suffered, assumed, or agreed to by the Insured Claimant;
  - (b) not Known to the Company, not recorded in the Public Records at Date of Policy, but Known to the Insured Claimant and not disclosed in writing to the Company by the Insured Claimant prior to the date the Insured Claimant became an Insured under this policy;
  - (c) resulting in no loss or damage to the Insured Claimant;
  - (d) attaching or created subsequent to Date of Policy (however, this does not modify or limit the coverage provided under Covered Risk 11, 13 or 14); or
  - (e) resulting in loss or damage that would not have been sustained if the Insured Claimant had paid value for the Insured Mortgage.
4. Unenforceability of the lien of the Insured Mortgage because of the inability or failure of an Insured to comply with applicable doing-business laws of the state where the Land is situated.
5. Invalidity or unenforceability in whole or in part of the lien of the Insured Mortgage that arises out of the transaction evidenced by the Insured Mortgage and is based upon usury or any consumer credit protection or truth-in-lending law.
6. Any claim, by reason of the operation of federal bankruptcy, state insolvency, or similar creditors' rights laws, that the transaction creating the lien of the Insured Mortgage, is
  - (a) a fraudulent conveyance or fraudulent transfer, or
  - (b) a preferential transfer for any reason not stated in Covered Risk 13(b) of this policy.
7. Any lien on the Title for real estate taxes or assessments imposed by governmental authority and created or attaching between Date of Policy and the date of recording of the Insured Mortgage in the Public Records. This Exclusion does not modify or limit the coverage provided under Covered Risk 11(b).

The above policy form may be issued to afford either Standard Coverage or Extended Coverage. In addition to the above Exclusions from Coverage, the Exceptions from Coverage in a Standard Coverage policy will also include the following Exceptions from Coverage:

**EXCEPTIONS FROM COVERAGE**

{Except as provided in Schedule B - Part II, {t{or T}his policy does not insure against loss or damage, and the Company will not pay costs, attorneys' fees or expenses, that arise by reason of:

## {PART I

{The above policy form may be issued to afford either Standard Coverage or Extended Coverage. In addition to the above Exclusions from Coverage, the Exceptions from Coverage in a Standard Coverage policy will also include the following Exceptions from Coverage:

1. (a) Taxes or assessments that are not shown as existing liens by the records of any taxing authority that levies taxes or assessments on real property or by the Public Records; (b) proceedings by a public agency that may result in taxes or assessments, or notices of such proceedings, whether or not shown by the records of such agency or by the Public Records.
2. Any facts, rights, interests, or claims that are not shown by the Public Records but that could be ascertained by an inspection of the Land or that may be asserted by persons in possession of the Land.
3. Easements, liens or encumbrances, or claims thereof, not shown by the Public Records.
4. Any encroachment, encumbrance, violation, variation, or adverse circumstance affecting the Title that would be disclosed by an accurate and complete land survey of the Land and not shown by the Public Records.
5. (a) Unpatented mining claims; (b) reservations or exceptions in patents or in Acts authorizing the issuance thereof; (c) water rights, claims or title to water, whether or not the matters excepted under (a), (b), or (c) are shown by the Public Records.
6. Any lien or right to a lien for services, labor or material not shown by the Public Records.}

## PART II

In addition to the matters set forth in Part I of this Schedule, the Title is subject to the following matters, and the Company insures against loss or damage sustained in the event that they are not subordinate to the lien of the Insured Mortgage:}

### 2006 ALTA OWNER'S POLICY (06-17-06)

#### EXCLUSIONS FROM COVERAGE

The following matters are expressly excluded from the coverage of this policy, and the Company will not pay loss or damage, costs, attorneys' fees, or expenses that arise by reason of:

1. (a) Any law, ordinance, permit, or governmental regulation (including those relating to building and zoning) restricting, regulating, prohibiting, or relating to
  - (i) the occupancy, use, or enjoyment of the Land;
  - (ii) the character, dimensions, or location of any improvement erected on the Land;
  - (iii) the subdivision of land; or
  - (iv) environmental protection;or the effect of any violation of these laws, ordinances, or governmental regulations. This Exclusion 1(a) does not modify or limit the coverage provided under Covered Risk 5.
  - (b) Any governmental police power. This Exclusion 1(b) does not modify or limit the coverage provided under Covered Risk 6.
2. Rights of eminent domain. This Exclusion does not modify or limit the coverage provided under Covered Risk 7 or 8.
3. Defects, liens, encumbrances, adverse claims, or other matters
  - (a) created, suffered, assumed, or agreed to by the Insured Claimant;
  - (b) not known to the Company, not recorded in the Public Records at Date of Policy, but known to the Insured Claimant and not disclosed in writing to the Company by the Insured Claimant prior to the date the Insured Claimant became an Insured under this policy;
  - (c) resulting in no loss or damage to the Insured Claimant;
  - (d) attaching or created subsequent to Date of Policy (however, this does not modify or limit the coverage provided under Covered Risk 9 and 10); or
  - (e) resulting in loss or damage that would not have been sustained if the Insured Claimant had paid value for the Title.
4. Any claim, by reason of the operation of federal bankruptcy, state insolvency, or similar creditors' rights laws, that the transaction vesting the Title as shown in Schedule A, is
  - (a) a fraudulent conveyance or fraudulent transfer; or
  - (b) a preferential transfer for any reason not stated in Covered Risk 9 of this policy.
5. Any lien on the Title for real estate taxes or assessments imposed by governmental authority and created or attaching between Date of Policy and the date of recording of the deed or other instrument of transfer in the Public Records that vests Title as shown in Schedule A.

The above policy form may be issued to afford either Standard Coverage or Extended Coverage. In addition to the above Exclusions from Coverage, the Exceptions from Coverage in a Standard Coverage policy will also include the following Exceptions from Coverage:

#### EXCEPTIONS FROM COVERAGE

This policy does not insure against loss or damage, and the Company will not pay costs, attorneys' fees or expenses, that arise by reason of:

{The above policy form may be issued to afford either Standard Coverage or Extended Coverage. In addition to the above Exclusions from Coverage, the Exceptions from Coverage in a Standard Coverage policy will also include the following Exceptions from Coverage:

1. (a) Taxes or assessments that are not shown as existing liens by the records of any taxing authority that levies taxes or assessments on real property or by the Public Records; (b) proceedings by a public agency that may result in taxes or assessments, or notices of such proceedings, whether or not shown by the records of such agency or by the Public Records.
2. Any facts, rights, interests, or claims that are not shown in the Public Records but that could be ascertained by an inspection of the Land or that may be asserted by persons in possession of the Land.
3. Easements, liens or encumbrances, or claims thereof, not shown by the Public Records.
4. Any encroachment, encumbrance, violation, variation, or adverse circumstance affecting the Title that would be disclosed by an accurate and complete land survey of the Land and that are not shown by the Public Records.
5. (a) Unpatented mining claims; (b) reservations or exceptions in patents or in Acts authorizing the issuance thereof; (c) water rights, claims or title to water, whether or not the matters excepted under (a), (b), or (c) are shown by the Public Records.
6. Any lien or right to a lien for services, labor or material not shown by the Public Records. }
7. {Variable exceptions such as taxes, easements, CC&R's, etc. shown here.}

## ALTA EXPANDED COVERAGE RESIDENTIAL LOAN POLICY – ASSESSMENTS PRIORITY (04-02-15)

### EXCLUSIONS FROM COVERAGE

The following matters are expressly excluded from the coverage of this policy and the Company will not pay loss or damage, costs, attorneys' fees or expenses which arise by reason of:

1. (a) Any law, ordinance, permit, or governmental regulation (including those relating to building and zoning) restricting, regulating, prohibiting, or relating to
  - (i) the occupancy, use, or enjoyment of the Land;
  - (ii) the character, dimensions, or location of any improvement erected on the Land;
  - (iii) the subdivision of land; or
  - (iv) environmental protection;or the effect of any violation of these laws, ordinances, or governmental regulations. This Exclusion 1(a) does not modify or limit the coverage provided under Covered Risk 5, 6, 13(c), 13(d), 14 or 16.
- (b) Any governmental police power. This Exclusion 1(b) does not modify or limit the coverage provided under Covered Risk 5, 6, 13(c), 13(d), 14 or 16.
2. Rights of eminent domain. This Exclusion does not modify or limit the coverage provided under Covered Risk 7 or 8.
3. Defects, liens, encumbrances, adverse claims, or other matters
  - (a) created, suffered, assumed, or agreed to by the Insured Claimant;
  - (b) not Known to the Company, not recorded in the Public Records at Date of Policy, but Known to the Insured Claimant and not disclosed in writing to the Company by the Insured Claimant prior to the date the Insured Claimant became an Insured under this policy;
  - (c) resulting in no loss or damage to the Insured Claimant;
  - (d) attaching or created subsequent to Date of Policy (however, this does not modify or limit the coverage provided under Covered Risk 11, 16, 17, 18, 19, 20, 21, 22, 23, 24, 27 or 28); or
  - (e) resulting in loss or damage that would not have been sustained if the Insured Claimant had paid value for the Insured Mortgage.
4. Unenforceability of the lien of the Insured Mortgage because of the inability or failure of an Insured to comply with applicable doing-business laws of the state where the Land is situated.
5. Invalidity or unenforceability in whole or in part of the lien of the Insured Mortgage that arises out of the transaction evidenced by the Insured Mortgage and is based upon usury, or any consumer credit protection or truth-in-lending law. This Exclusion does not modify or limit the coverage provided in Covered Risk 26.
6. Any claim of invalidity, unenforceability or lack of priority of the lien of the Insured Mortgage as to Advances or modifications made after the Insured has Knowledge that the vestee shown in Schedule A is no longer the owner of the estate or interest covered by this policy. This Exclusion does not modify or limit the coverage provided in Covered Risk 11.
7. Any lien on the Title for real estate taxes or assessments imposed by governmental authority and created or attaching subsequent to Date of Policy. This Exclusion does not modify or limit the coverage provided in Covered Risk 11(b) or 25.
8. The failure of the residential structure, or any portion of it, to have been constructed before, on or after Date of Policy in accordance with applicable building codes. This Exclusion does not modify or limit the coverage provided in Covered Risk 5 or 6.
9. Any claim, by reason of the operation of federal bankruptcy, state insolvency, or similar creditors' rights laws, that the transaction creating the lien of the Insured Mortgage, is
  - (a) a fraudulent conveyance or fraudulent transfer, or
  - (b) a preferential transfer for any reason not stated in Covered Risk 27(b) of this policy.
10. Contamination, explosion, fire, flooding, vibration, fracturing, earthquake, or subsidence.
11. Negligence by a person or an Entity exercising a right to extract or develop minerals, water, or any other substances.



# Fidelity National Title Company

5000 Van Nuys Blvd., Suite 500, Sherman Oaks, CA 91403  
Phone: (818) 881-7800 • Fax: (818) 776-8528

5550  
SHEET 2  
SCALE 1" = 40'

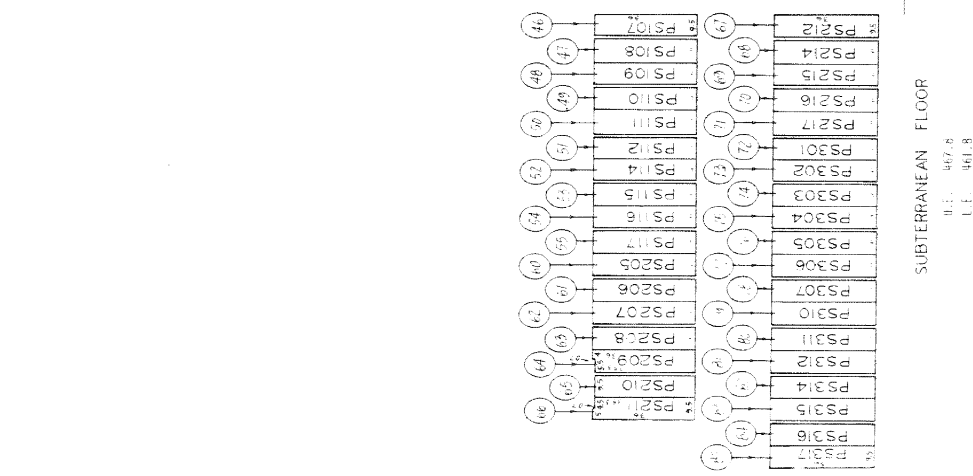
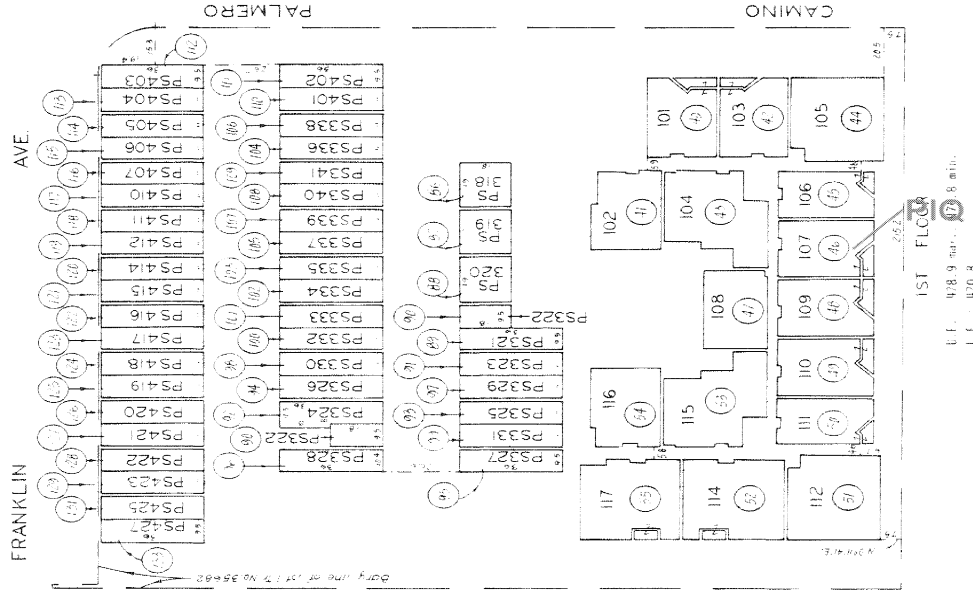
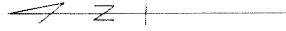

See typical building floor plan for  
unit dimensions and details.

**SUBDIVISION OF AIRSPACE**  
**CONDOMINIUM TRACT NO. 35682**

SEE MAPS: S.P. 40, 13, 17, 20. Call space in  
County of Orange, California at R. Property Line  
preparation of Franklin Ave.  
Division, 441, 012  
1970

ASSESSOR'S MAP  
COUNTY OF LOS ANGELES, CALIF.

This map/plat is being furnished as an aid in locating the herein described Land in relation to adjoining streets, natural boundaries and other land, and is not a survey of the land depicted. Except to the extent a policy of title insurance is expressly modified by endorsement, if any, the Company does not insure dimensions, distances, location of easements, acreage or other matters shown thereon.

This map/plat is being furnished as an aid in locating the herein described Land in relation to adjoining streets, natural boundaries and other land, and is not a survey of the land depicted. Except to the extent a policy of title insurance is expressly modified by endorsement, if any, the Company does not insure dimensions, distances, location of easements, acreage or other matters shown thereon



STATEMENT OF INFORMATION

CONFIDENTIAL INFORMATION FOR YOUR PROTECTION

Escrow No.: 00370689-994-VNO-1AW

Title No.:

Completion of this statement expedites your application for title insurance, as it assists in establishing identity, eliminating matters affecting persons with similar names and avoiding the use of fraudulent or forged documents. Complete all blanks (please print) or indicate "none" or "N/A". If more space is needed for any item(s), use the reverse side of the form. Each party (and spouse/domestic partner, if applicable) to the transaction should personally sign this form.

NAME AND PERSONAL INFORMATION

Form fields for Name and Personal Information: First Name, Middle/Maiden Name, Last Name, Date of Birth, Home Phone, Business Phone, Birthplace, Cell Phone, Fax, Email, Social Security No., Driver's License No., List any other name you have used or been known by, State of residence.

Are you currently married? IF YES, COMPLETE THE FOLLOWING INFORMATION:

Form fields for Married Information: Date and place of marriage, Spouse (First Name, Middle/Maiden Name, Last Name, Date of Birth, Home Phone, Business Phone, Birthplace, Cell Phone, Fax, Email, Social Security No., Driver's License No., List any other name you have used or been known by, State of residence).

Are you currently a registered domestic partner? IF YES, COMPLETE THE FOLLOWING INFORMATION:

Form fields for Domestic Partner Information: Domestic Partner (First Name, Middle/Maiden Name, Last Name, Date of Birth, Home Phone, Business Phone, Birthplace, Cell Phone, Fax, Email, Social Security No., Driver's License No., List any other name you have used or been known by, State of residence).

CHILDREN

Form fields for Children: Child Name, Date of Birth (two entries).

(if more space is required, use reverse side of form)

RESIDENCES (LAST 10 YEARS)

Form fields for Residences: Number & Street, City, From (date) to (date) (two entries).

(if more space is required, use reverse side of form)

OCCUPATIONS/BUSINESSES (LAST 10 YEARS)

Form fields for Occupations/Businesses: Firm or Business Name, Address, From (date) to (date) (two entries).

(if more space is required, use reverse side of form)

**SPOUSE'S/DOMESTIC PARTNER'S OCCUPATIONS/BUSINESSES (LAST 10 YEARS)**

---

Firm or Business Name	Address	From (date) to (date)
_____	_____	_____
Firm or Business Name	Address	From (date) to (date)
_____	_____	_____

(if more space is required, use reverse side of form)

**PRIOR MARRIAGE(S)**

Any prior marriages for either spouse? \_\_\_\_\_ **IF YES, COMPLETE THE FOLLOWING INFORMATION:**

Prior spouse's (Party A) name: _____	Prior Spouse of Party A: _____
Marriage ended by: <input type="checkbox"/> Death <input type="checkbox"/> Divorce	Date of Death/Divorce: _____
Prior spouse's (Party B) name: _____	Prior Spouse of Party B: _____
Marriage ended by: <input type="checkbox"/> Death <input type="checkbox"/> Divorce	Date of Death/Divorce: _____

(if more space is required, use reverse side of form)

**PRIOR DOMESTIC PARTNERSHIP(S)**

Any prior domestic partnerships for either person? \_\_\_\_\_ **IF YES, COMPLETE THE FOLLOWING INFORMATION:**

Prior partner's name: _____	Prior Partner: _____
Partnership ended by: <input type="checkbox"/> Death <input type="checkbox"/> Dissolution <input type="checkbox"/> Nullification <input type="checkbox"/> Termination	Date of Death/Dissolution/etc.: _____
Prior partner's name: _____	Prior Partner: _____
Partnership ended by: <input type="checkbox"/> Death <input type="checkbox"/> Dissolution <input type="checkbox"/> Nullification <input type="checkbox"/> Termination	Date of Death/Dissolution/etc.: _____

(if more space is required, use reverse side of form)

**INFORMATION ABOUT THE PROPERTY**

Buyer intends to reside on the property in this transaction:  Yes  No

**OWNER TO COMPLETE THE FOLLOWING ITEMS**

Street Address of Property in this transaction: \_\_\_\_\_

The land is  unimproved; or improved with a structure of the following type:  A Single or 1-4 Family  Condo Unit  Other

Improvements, remodeling or repairs to this property have been made within the past six (6) months:  Yes  No

If yes, have all costs for labor and materials arising in connection therewith been paid in full?  Yes  No

Any current loans on property? \_\_\_\_\_ **IF YES, COMPLETE THE FOLLOWING INFORMATION:**

Lender: _____	Loan Amount: _____	Loan <u>Account No.:</u> _____
<u>Lender:</u> _____	Loan Amount: _____	Loan <u>Account No.:</u> _____

The undersigned declare, under penalty of perjury, that the foregoing is true and correct.

IN WITNESS WHEREOF, the undersigned have executed this document on the date(s) set forth below.

_____ Signature	_____ Date
_____ Print Name	
_____ Signature	_____ Date
_____ Print Name	

**(NOTE: IF APPLICABLE, BOTH SPOUSES/DOMESTIC PARTNERS MUST SIGN.)**

**THANK YOU.**



**Fidelity National Title Company**

5000 Van Nuys Blvd., Suite 500, Sherman Oaks, CA 91403  
Phone: (818) 881-7800 • Fax: (818) 776-8528

**CREDIT LINE / EQUITY LINE OF CREDIT CLOSURE REQUEST**

Date: \_\_\_\_\_

To: \_\_\_\_\_

\_\_\_\_\_

\_\_\_\_\_

\_\_\_\_\_

**Attention:** Payoff Dept.

**Reference:** Account/Loan # \_\_\_\_\_

**Property Address:** 1745 Camino Palmero Street No. 107, Los Angeles, CA 90046

To Whom It May Concern:

Please accept this letter as a request to close/freeze the above-referenced credit line or equity line of credit as of this date.

I/We agree not to request any advances on this account on or after the date of this letter.

You will be receiving payment in full from the proceeds of our escrow transaction. Upon receipt of payoff, please send your Reconveyance or Release of Lien to:

**Fidelity National Title Company**

5000 Van Nuys Blvd., Suite 500

Sherman Oaks, CA 91403

Attn: Albert Wassif

Ref: 00370689-994-1AW

Sincerely,

\_\_\_\_\_  
\_\_\_\_\_  
\_\_\_\_\_

(All borrowers must sign)



# Fidelity National Title Company

5000 Van Nuys Blvd., Suite 500, Sherman Oaks, CA 91403  
Phone: (818) 881-7800 • Fax: (818) 776-8528

## OWNER'S DECLARATION

Order No.: 00370689-994-VNO-1AW

Property Address: 1745 Camino Palmero Street No. 107, Los Angeles, CA 90046

The undersigned hereby declares as follows:

1. (Fill in the applicable paragraph and strike the other)

a. Declarant ("Owner") is the owner or lessee, as the case may be, of certain premises located at 1745 Camino Palmero Street No. 107, Los Angeles, CA 90046, further described as follows: See Preliminary Report/Commitment No. 00370689-994-VNO-1AW for full legal description (the "Land").

b. Declarant is the \_\_\_\_\_ of \_\_\_\_\_ ("Owner"), which is the owner or lessee, as the case may be, of certain premises located at 1745 Camino Palmero Street No. 107, Los Angeles, CA 90046, further described as follows: See Preliminary Report/Commitment No. 00370689-994-VNO-1AW for full legal description (the "Land").

2. (Fill in the applicable paragraph and strike the other)

a. During the period of six months immediately preceding the date of this declaration no work has been done, no surveys or architectural or engineering plans have been prepared, and no materials have been furnished in connection with the erection, equipment, repair, protection or removal of any building or other structure on the Land or in connection with the improvement of the Land in any manner whatsoever.

b. During the period of six months immediately preceding the date of this declaration certain work has been done and materials furnished in connection with \_\_\_\_\_ upon the Land in the approximate total sum of \$\_\_\_\_\_, but no work whatever remains to be done and no materials remain to be furnished to complete the construction in full compliance with the plans and specifications, nor are there any unpaid bills incurred for labor and materials used in making such improvements or repairs upon the Land, or for the services of architects, surveyors or engineers, except as follows: \_\_\_\_\_. Owner, by the undersigned Declarant, agrees to and does hereby indemnify and hold harmless Fidelity National Title Company against any and all claims arising therefrom.

3. Owner has not previously conveyed the Land; is not a debtor in bankruptcy (and if a partnership, the general partner thereof is not a debtor in bankruptcy); and has not received notice of any pending court action affecting the title to the Land.

4. Except as shown in the above-referenced Preliminary Report/Commitment, there are no unpaid or unsatisfied mortgages, deeds of trust, Uniform Commercial Code financing statements, regular assessments, special assessments, periodic assessments or any assessment from any source, claims of lien, special assessments, or taxes that constitute a lien against the Land or that affect the Land but have not been recorded in the public records. There are no violations of the covenants, conditions and restrictions as shown in the above-referenced Preliminary Report/Commitment.

5. The Land is currently in use as \_\_\_\_\_; \_\_\_\_\_ occupy/occupies the Land; and the following are all of the leases or other occupancy rights affecting the Land:

\_\_\_\_\_

6. There are no other persons or entities that assert an ownership interest in the Land, nor are there unrecorded easements, claims of easement, or boundary disputes that affect the Land.

7. There are no outstanding options to purchase or rights of first refusal affecting the Land.

8. Between the most recent Effective Date of the above-referenced Preliminary Report/Commitment and the date of recording of the Insured Instrument(s), Owner has not taken or allowed, and will not take or allow, any action or inaction to encumber or otherwise affect title to the Land.

This declaration is made with the intention that Fidelity National Title Company (the "Company") and its policy issuing agents will rely upon it in issuing their title insurance policies and endorsements. Owner, by the undersigned Declarant, agrees to indemnify the Company against loss or damage (including attorneys fees, expenses, and costs) incurred by the Company as a result of any untrue statement made herein.

I declare under penalty of perjury that the foregoing is true and correct and that this declaration was executed on \_\_\_\_\_ at \_\_\_\_\_.

Signature: \_\_\_\_\_

## ALTA Information Collection Form

Page 1 of 4

Under 31 U.S.C. § 5326(a), the Treasury Department's Financial Crimes Enforcement Network (FinCEN) issued a Geographic Targeting Order to title insurance companies requiring the collection of beneficial ownership information for certain real estate transactions.

Please complete the below questionnaire. This Company will rely on the answers provided to meet its reporting obligations.

### Who is completing this form?

Name	Position/Title	Company/Law Firm	
Postal Address (Headquarters)	City	State	Zip
Phone	Email	Fax	

### Transactional Information

Property Address (If Multiple properties see NOTE below):			
City	State	Zip	County
Date of Settlement	Total purchase price (if multiple properties see NOTE below)		
Type of Transaction:	<input type="checkbox"/> Residential (1-4 family)	<input type="checkbox"/> Commercial	Bank Financing: <input type="checkbox"/> Yes <input type="checkbox"/> No
Purchase type:	<input type="checkbox"/> Natural Person	<input type="checkbox"/> Corporation	<input type="checkbox"/> LLC <input type="checkbox"/> Partnership <input type="checkbox"/> Other

**NOTE:** If more than one property is purchased, list each address and purchase price as an addendum.

### Purchase Funds Information

Total Amount paid by below instruments: \$	
Which type of Monetary Instruments were used (Use check boxes below)	
<input type="checkbox"/> U.S. Currency (Paper money & coin)	
<input type="checkbox"/> Foreign Currency	Country:
<input type="checkbox"/> Cashier's check(s)	<input type="checkbox"/> Money order(s)
<input type="checkbox"/> Certified check(s)	<input type="checkbox"/> Personal or Business check(s)
<input type="checkbox"/> Wire or other funds transfer(s)	<input type="checkbox"/> Virtual Currency

## ALTA Information Collection Form

Page 2 of 4

### Individual Primarily Representing Purchaser

*(Define as the individual authorized by the entity to enter into legally binding contracts).*

Attach Legible copy of government issued identification (i.e., passport, driver's license, etc.)			
Type of ID	Issuing State or Country	Gov't ID Number	
Last Name	First Name	M.I.	
Date of Birth	Occupation	Individual Taxpayer ID # <i>(if none write N/A)</i>	% of ownership
Address	City	State	Zip

### Purchasing Entity Name & Address

Name of Purchaser			
Taxpayer ID Number or EIN <i>(if none write N/A)</i>		Doing Business Name (DBA) <i>(if none write N/A)</i>	
Address	City	State	Zip

**Complete the information below if the real estate purchase is being made by a corporation, LLC, partnership, other legal entity. (Do not report trusts.)**

#### For Corporations, LLCs, Partnerships and Other Entities provide the information for:

- Each **BENEFICIAL OWNER** defined as an individual who, directly or indirectly, owns 25% or more of the equity interests of the Purchaser.
- If a legal entity or a series of legal entities own the equity interests of the Purchaser, provide information for each **BENEFICIAL OWNER**, of each legal entity in the series of legal entities.

**(Note: It is NOT necessary to complete the address fields if the information is on a legible copy of the government issued ID submitted to the title company.)**

## ALTA Information Collection Form

Page 3 of 4

Attach Legible copy of government issued identification (i.e., passport, driver's license, etc.)			
Type of ID	Issuing State or Country	Gov't ID Number	
Last Name	First Name	M.I.	
Date of Birth	Occupation	Individual Taxpayer ID # <i>(if none write N/A)</i>	% of ownership
Address	City	State	Zip

Attach Legible copy of government issued identification (i.e., passport, driver's license, etc.)			
Type of ID	Issuing State or Country	Gov't ID Number	
Last Name	First Name	M.I.	
Date of Birth	Occupation	Individual Taxpayer ID # <i>(if none write N/A)</i>	% of ownership
Address	City	State	Zip

Attach Legible copy of government issued identification (i.e., passport, driver's license, etc.)			
Type of ID	Issuing State or Country	Gov't ID Number	
Last Name	First Name	M.I.	
Date of Birth	Occupation	Individual Taxpayer ID # <i>(if none write N/A)</i>	% of ownership
Address	City	State	Zip

Attach Legible copy of government issued identification (i.e., passport, driver's license, etc.)			
Type of ID	Issuing State or Country	Gov't ID Number	
Last Name	First Name	M.I.	
Date of Birth	Occupation	Individual Taxpayer ID # <i>(if none write N/A)</i>	% of ownership
Address	City	State	Zip

Attach Legible copy of government issued identification (i.e., passport, driver's license, etc.)
--

## ALTA Information Collection Form

Page 4 of 4

Type of ID		Issuing State or Country		Gov't ID Number	
Last Name			First Name		M.I.
Date of Birth	Occupation		Individual Taxpayer ID # <i>(if none write N/A)</i>		% of ownership
Address		City		State	Zip

I declare that to the best of my knowledge, the information I have furnished is true, correct and complete. I understand that this Title Company will rely on this information for the purposes of completing any reports made pursuant to an obligation under 31 U.S.C. § 5326(a),

Signature:	Date:
Type or Print Name:	Title: